



**Mini-equipment “GOTEPRI” For the application of highly decorative paints, with perfect stipped or smooth finish etc.**



# Product Guide

DESCRIPTION.....	4
INSTRUCTIONS.....	5
1. LOADING THE PAINT.....	5
2. STARTING WORK.....	7
3. USE OF HIGHLY DECORATIVE PAINTS.....	8
4. RESTORING DETERIORATED STIPPLED SURFACE.....	10
5. SMOOTH FINISH.....	11
6. WORKING ON WALLS AND CEILING.....	11
7. CONVENTIONAL PISTOL.....	12
CLEANING MAINTENANCE.....	12
1. EMPTYING THE PAINT CONTAINER.....	12
2. CLEAN THE EQUIPMENT.....	13
3. CLEANING THE INSIDE OF THE MACHINE.....	13
4. OPENING AND CLOSING THE PAINT CONTAINER COVER (4).....	13
5. OBSTRUCTION IN THE DISTRIBUTION SYSTEM.....	13
PRACTICAL ADVICE FOR GOOD OPERATION.....	14
SECURITY WARNINGS.....	15
GUARANTEE.....	16

**Important:** On receipt of this product and before using the equipment read carefully this manual. Keep the manual in a secure place for future reference.

## DESCRIPTION

Handling this equipment is simple allowing precise adjustment requiring only the regulation of the paint container air pressure and the air flow through the pistol.

The equipment functions by the introduction of air into the paint container via the pressure regulator. The control of the air, via the air flow regulator, allows adjustment of the paint drop.

The equipment allows multiple finishes using all types of highly decorative paints (except sandy types) providing a perfect finish with any type of stippled paint.

### Componentes fundamentales.

- 1- Base
- 2- Paint Container
- 3- Closing locks
- 4- Paint Container cover
- 5- Suction valve
- 6- Loading cap
- 7- Pressure guage
- 8- Funnel Extension
- 9- Funnel
- 10- Grid Filter
- 11- Filter Seat Washer
- 12- Air Flow Regulator
- 13- Pressure Regulator
- 14- Safety Valve
- 15- Air Stop-cock
- 16- Accessory System

### Accessories include:

- 5 m Hose.
- Aluminium Paint Container
- Hard Bristle Brush
- Soft Bristle Brush
- Test Board

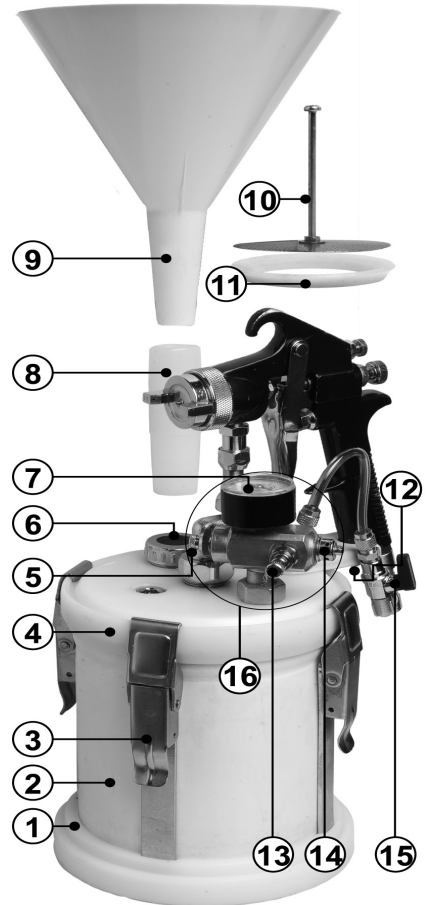

# INSTRUCTIONS

## 1. Loading the paint

Loading the paint can be carried out without opening the paint container.

- 1.1.** Before beginning the load ensure that the air stopcock (15) is closed, horizontal position (photo 1); next remove the suction valve (5) and open the pressure regulator (13) rotating anticlockwise 2-3 turns (photo 2)

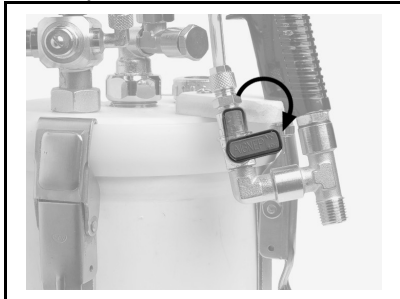

photo 1

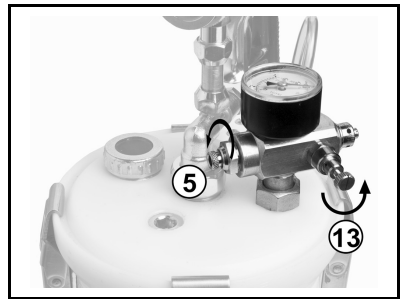
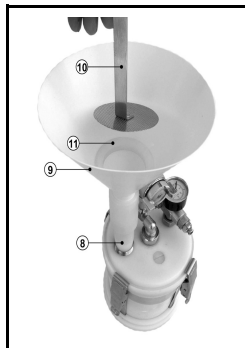

photo 2

- 1.2.** Unscrew the loading cap (6) of the paint container, Insert the funnel (9) and its extension (8) included with the equipment. If it is necessary to filter the material (for example: stippled paste) use the grid filter (10) and the filter seat washer (11).



**1.3.** Once the air hose has been connected to the pistol and the compressor start the compressor

**1.4.** Fill the funnel with the paint to be used.

Open the air stop-cock, vertical position (photo 3) and the paint will be absorbed into the paint container. This operation can be assisted by using a spatula or a brush.

Next close the air stop-cock (photo 4).

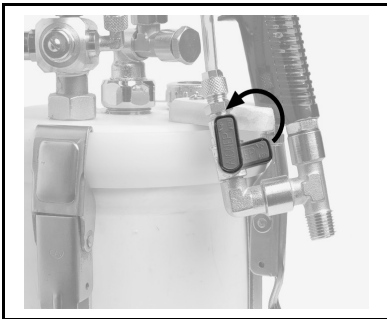

photo 3

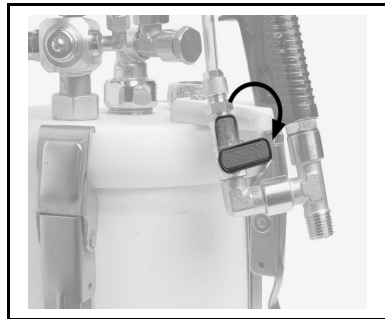

photo 4

**Important:**

**The paint container is filled with two funnel loads. Do not attempt to load more as this could obstruct the distribution of air.** In [the](#) case of such an obstruction see [page 12](#).

**1.5.** If this is the first funnel load repeat section 1.4 once more to fill the paint container.

**1.6.** Remove the funnel extension and funnel and close the loading cap

**1.7.** To complete close the suction valve (5) and the pressure regulator (13).

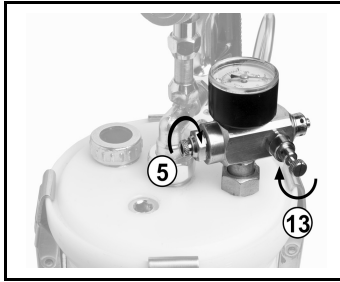

**Advice:** When finished the paint in the paint container and the funnel can be returned to the paint container and closed to prevent the paint from drying.

## 2. Starting work

Before starting the work one should consider the 2 adjusters found on the upper part of the pistol grip. The first is the “fan regulator” which should initially be closed and then adjusted to the required stippled paint and surface to be painted. The 2<sup>nd</sup> adjuster is the needle regulator. This should always be fully open (refer to the pistol manual).

**2.1.** Verify that the suction valve (5), pressure regulator (13) (photo 5) and air flow regulator (12) (photo 6) are closed and open the air stopcock, vertical position. (Photo 7).

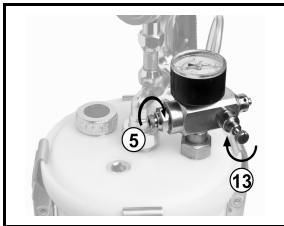

photo 5

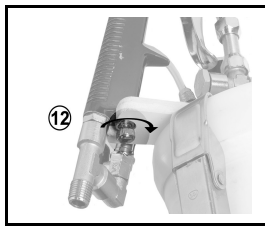

photo 6

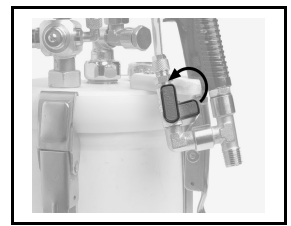

photo 7

**2.2.** Next open little by little the pressure regulator (13) until the pressure gauge (7) shows 0.5 bar.

It is necessary to regulate the air pressure dependant on the viscosity and the characteristics of the paint. (higher viscosity –

higher pressure, less viscosity – less pressure) turning the adjuster to the left increases pressure – to the right reduces pressure.

The pressure gauge (7) indicates the current pressure in the paint container and the safety valve (14) prevents overpressure in the paint container

It is recommended to work the equipment with pressures up to 2 bar

- 2.3.** Apply slight pressure to the to the pistol trigger to produce a paint spray and the open smoothly the air flow regulator of the pistol (12), until the required paint characteristics are obtained.

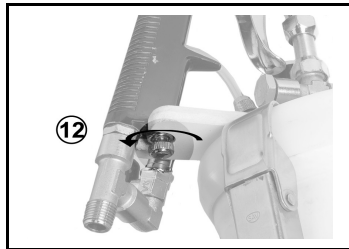

To work comfortably support the equipment with both hands using one hand to hold the pistol grip and the other to support the base of the paint container.

**Important:** If painting large surfaces it is beneficial to occasionally clean the nozzle of the pistol to remove any material that has accumulated. Press the trigger such that only air is emitted and at the same time clean the nozzle with a plastic brush and water.

### **VERY IMPORTANT!**

Before disconnecting the air hose of the gun it is necessary to close the air stop-cock (photo 1). **This will avoid blockages in the circulation of the air.**

### 3. Use of highly decorative paints

The equipment can apply all highly decorative paints and pastes on the market except sand paints.

- 3.1. To begin fill the paint container as described in section 1 loading the material using the funnel without the grid filter (10).
- 3.2. To paint repeat the steps described in the section starting work (2.1. - 2.3.)
- 3.3. Lastly apply the required effect using spatula, sponge or other tools on the wet paint.

#### **Ejemplo: "Terre Fiorentina"**

**Step 1:** Prepare the surface.

**Step 2:** Load the **"Terre Fiorentina"** using the funnel without the grid filter and repeat the actions described in section 1 "Loading the Paint"

**Step 3:** Perform the steps described in section 2 "Starting Work". Set up the pistol for large droplet (More pressure, less air) and spray the **"Terre Fiorentina"** on the prepared surface of the wall.



**Step 4:**

Pass the flexible plastic spatula on the wall while the paint is still wet.

**Step 5:**

Examine result.

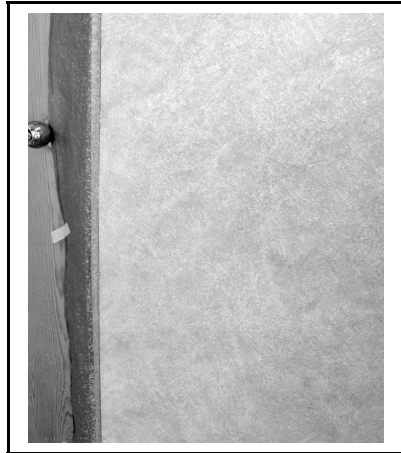

#### **4. Restoring deteriorated stippled surface.**

**4.1.** Load the paint container (2) with the stippled paste as described in section 1 “Loading the paint” using the funnel (9) with the filter seat washer (11) and the grid filter (10) included with the equipment.

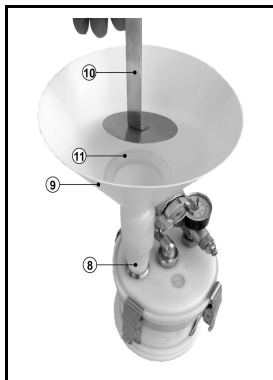

**4.2.** To start work repeat the steps described in the section 2 “Starting Work”.

**4.3.** Using the pressure regulator (13) and the air flow regulator (12), obtain the required droplet (with tail, without tail, fat, fine, starred,

without starring, puddled, without puddling etc.) dependant on the thickness of the paste (consult the table of adjustment).

### Table of adjustments.

	Applying stippling		Restoring stippling	
	Manometer	Regulating flow of air	Manometer	Regulating flow of air
<b>Fine stippling</b> Less pressure more airflow.	1 Bar.	Adjust air flow regulator (between min to max) to obtaining the required droplet	0 – 0,5 Bar.	Adjust air flow regulator (between min to max) to obtaining the required droplet
<b>Fat stippling</b> more pressure less airflow.	2,5 Bar.	Adjust air flow regulator (between min to max) to obtaining the required droplet	1 Bar.	Adjust air flow regulator (between min to max) to obtaining the required droplet

**Practical Advice:** To regulate the droplet for minimum diameter set minimum pressure and minimum air-flow.

## 5. Smooth finish

**5.1.** Load the paint container (2) as described in section 1 “Loading the paint”.

**5.2.** To start work repeat the steps described in the section 2 “Starting Work”.

### Practical Advice:

To avoid fogging when applying a smooth paint it is recommended that the paint be diluted with a little water. Apply the water according to the viscosity of the paint, adjust the pressure and air volume to ensure that the paint is not projected in suspension.

## 6. Working on walls and ceiling.

Open the paint container cover (See section 7.4); at the end of the suction tube (B) is found 2 paint absorbers.

In order to paint on a wall place the plug (A) at the rear. For painting on the ceiling place the plug at the front (right image).

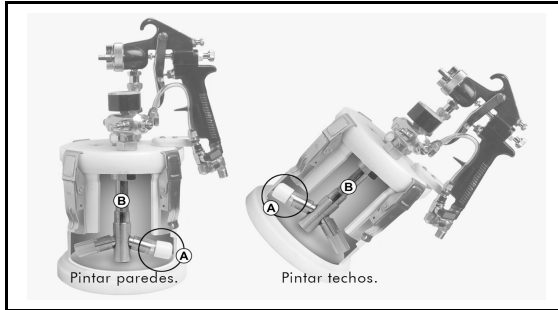

**The plug should always be placed as shown in the above image in order to be able to work in the position shown.**

## 7. Conventional pistol

In order to utilise the pistol as a conventional paint sprayer it is necessary to disconnect the Gotepri paint container and mount the aluminium paint container, included with the equipment (See following image).



Included is the instruction manual of the conventional saint sprayer.

## Cleaning Maintenance

In order to ensure good operation and preservation of the equipment it

is recommended, once work is finished, to empty the surplus material in the paint container and clean and dry the inside of the equipment.

## **1. Emptying the Paint Container**

This can be performed by fully opening the cover of the paint container and pouring out the content.

## **2. Clean the equipment.**

Fill the paint container with hot water and agitate and then remove the dirt from the equipment by controlling the air using the pistol trigger to clean the pipe-work of the equipment.

## **3. Cleaning the inside of the machine**

Introduce air into the paint container through the pressure regulator (13). Press the pistol trigger so that the air dries the equipment.

## **4. Opening and closing the paint container cover (4).**

Before opening the paint container cover (4), ensure that there is no pressure in the paint container. Next open the closing locks (2 by opposite 2). Now hold the base and rotate the cover right to left to unscrew.

### **Practical Advice:**

Sometimes the cover might remain stuck due to the paint. In this case give the cover some gentle blows to separate. To close the paint container cover hold the base and turn the cover carefully left to right then close the closing locks (2 by opposite 2).

## **5. Obstruction in the distribution system**

If the equipment does not function well it is possible that the interior filter that protects the distributor block is blocked. In this case loosen the nut (A) near the internal part of the cover (photo 8) to remove the filter (B). Wash the filter (B) and return to the original position (photo 9).

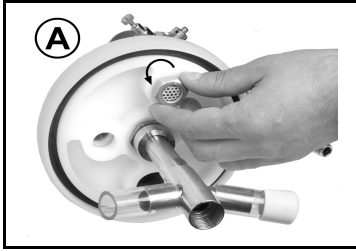

Photo 8

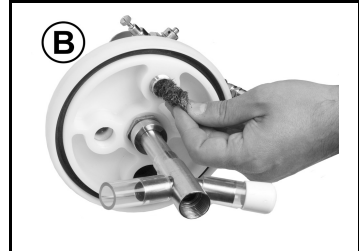
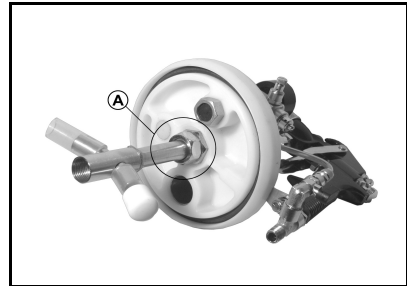

Photo 9

## NEVER ADJUST THE SAFETY VALUE

### Practical Advice for Good Operation

1. Clean and maintain the equipment after each use.
2. The nut (A), in photo opposite, fixing the interior suction pipe should be loosely fitted to the cover avoiding the possibility that it might unscrew the load pipe of the paint container cover.



### TABLE OF SOLUTIONS

PROBLEM	POSSIBLE CAUSE	SOLUCIÓN
No paint from the pistol	1. The filter is blocked.	1. Loosen the nut (A) near the internal part of the cover (photo 8), to remove the filter (B). Wash the filters (B) and return to the original position (photo 9).
	2. Little effective painting	2. A gentle blow to the lower part of the paint container will allow the paint to descend to the bottom of the paint

	3. A lack of pressure in the paint container.	container. Alternatively reload the paint container. 3. Increase the pressure.
The unit cannot pass the paint	The interior filter that protects the distributor block is blocked	Loosen the nut by the internal part of the cover (photo 8), remove and clean the filters and return to the original position (photo 9).
The paint drops fall too close to the pistol	The pistol has accumulated dry paint on the air cap.	Press the trigger of the pistol such that only air leaves the nozzle. At the same time with a plastic brush clean the nozzle.
Excessive paint fog.	Air flow too high	Reduce the air flow using the air flow regulator. (12).
Air leak from the cover	The seat of the cover is dirty.	Open the paint container cover and clean the internal parts

## Security Warnings

Read carefully this manual before carrying out any operations with this equipment. In case of any doubt about the use of the equipment contact by e-mail [info@gotepri.com](mailto:info@gotepri.com).

1. Before using the equipment read and understand the use of the compressor.
2. Ensure that you have correctly connected, with proper filters, the equipment to the compressor. Ensure that the hoses are in perfect condition.
3. Do not use pressures in excess of those recommended.
4. Do not point the pistol at any person or animal.
5. Do not use hydrocarbon based clearing materials on this equipment since they might chemically react with the aluminium of the pistol

which could result in a dangerous explosion.

6. If you have any doubts about using any products with this equipment consult the information provided by the paint manufacturer.
7. Before disassembling and clearing this equipment ensure that you have disconnected the power supply.

**The equipment has been designed to perform the functions presented in this manual. The use for a different purpose will not be recognised. The MANUFACTURER will be allowed to change or replace any part of the original equipment for reasons of aesthetics, design etc. without such changes implying any change in technical characteristics. The MANUFACTURER is free of all responsibility in the case of unsuitable use that does not conform to the described instructions of use in this manual.**

## **Guarantee**

This product is tested and guaranteed for a period of 24 months from the date of delivery. This guarantee is limited to all clients who have fulfilled all contractual and administrative obligations, moreover the installation and the use of the product must be in compliance with the instructions provided in this manual. Under the terms of this guarantee, the Manufacturer shall repair or replace free of charge all components which are proven to be defective at source or which develop faults within the period of guarantee.

The guarantee does not cover labour costs for technical service operations, which will be duly charged. The guarantee also excludes all responsibility on the part of the Manufacturer for direct or indirect loss or damage to persons or things deriving from incorrect operation or servicing of the product. The guarantee excludes all components subject to normal wear.

Furthermore, the guarantee excludes all costs for transport, inspection, removal, and re-assembly incurred by the Manufacturer's service personnel when faults are not imputable to defects in material or assembly, and all costs thus incurred shall be duly charged.